



वर्गीय अपेक्षाएं के लिए मानक  
टीईसी 79XXX:2026

STANDARD FOR GENERIC REQUIREMENTS  
TEC 79XXX:2026

---

फिक्स्ड वायरलेस फोन  
FIXED WIRELESS PHONE



---

दूरसंचार अभियांत्रिकी केंद्र  
खुर्शीदलाल भवन, जनपथ, नई दिल्ली-110001, भारत  
TELECOMMUNICATION ENGINEERING CENTRE  
KHURSHID LAL BHAWAN, JANPATH, NEW DELHI-110001, INDIA

[www.tec.gov.in](http://www.tec.gov.in)

© टीईसी, 2026

© TEC, 2026

इस सर्वाधिकार सुरक्षित प्रकाशन का कोई भी हिस्सा, दूरसंचार अभियांत्रिकी केंद्र, नई दिल्ली की लिखित स्वीकृति के बिना, किसी भी रूप में या किसी भी प्रकार से जैसे -इलेक्ट्रॉनिक, मैकेनिकल, फोटोकॉपी, रिकॉर्डिंग, स्कैनिंग आदि रूप में प्रेषित, संग्रहीत या पुनरुत्पादित न किया जाए।

All rights reserved and no part of this publication may be reproduced, stored in a retrieval system or transmitted, in any form and by any means - electronic, mechanical, photocopying, recording, scanning or otherwise, without written permission from the Telecommunication Engineering Centre, New Delhi.

**Release:** \_\_\_\_\_, 2026

**Price: Free of Cost**

## FOREWORD

Telecommunication Engineering Centre (TEC) is the technical arm of Department of Telecommunications (DOT), Government of India. Its activities include:

- Framing of TEC Standards for Generic Requirements for a Product/Equipment, Standards for Interface Requirements for a Product/Equipment, Standards for Service Requirements & Standard document of TEC for Telecom Products and Services
- Formulation of Essential Requirements (ERs) under Mandatory Testing and
- Certification of Telecom Equipment (MTCTE)
- Field evaluation of Telecom Products and Systems
- Designation of Conformity Assessment Bodies (CABs)/Testing facilities
- Testing & Certification of Telecom products
- Adoption of Standards
- Support to DoT on technical/technology issues

For the purpose of testing, four Regional Telecom Engineering Centers (RTECs) have been established which are located at New Delhi, Bangalore, Mumbai, and Kolkata.

## ABSTRACT

This document specifies the Generic Requirements (GR) of 'Fixed Wireless Phone' connected to the Indian Telecom Network. This document covers the Generic Requirements of Fixed Wireless Phone for supporting speech communication over mobile networks using SIM-based access. It covers its facilities, features and performance requirements for providing basic telephony and data services as an alternative to traditional Public Switched Telephone Networks (PSTN), particularly in areas lacking wired or wireless local loop infrastructure, including remote, hilly, temporary, and disaster-affected locations.

## CONTENTS

Clause	Particulars	Page No.
	History Sheet	5
	References	6
Chapter -1		
1.1	Introduction	9
1.2	Description	9
1.3	Functional Requirements	13
1.4	Interface Requirements	15
1.5	Quality Requirements	27
1.6	EMI/EMC Requirements	27
1.7	Safety Requirements	30
1.8	Security Requirements	30
Chapter -2		
2.1	Information for the procurer of product	31
	Abbreviations	32

## HISTORY SHEET

Sl. No.	Standard GR No.	Title	Remarks
1.	TEC 79XXX:2026	Standard for Generic Requirements for Fixed Wireless Phone	New Document

## CONVENTIONS

In this document, requirements are classified as follows:

- The keywords "shall" or "is/are required to" indicate a requirement or requirements, which must be mandatorily complied and from which no deviation is permitted, if conformance to this document is to be claimed;
- The keyword "should" indicates a recommended requirement, which is not mandatory for claiming conformance to this document. However, its implementation is strongly advised as it represents best practices or preferred functionality; and
- The keywords "Optional" or "may" indicate an optional requirement, which is permissible for exclusion from mandatory compliance, unless the said requirement is claimed to be complied by the vendor. These terms are not intended to imply that the vendor's implementation must provide the option; it means the vendor may optionally provide the feature and still claim conformance with this document.

## REFERENCES

S. N.	Document No.	Title/Document Name
1.	3GPP TS 38.521-1	5G NR; User Equipment (UE) conformance specification; Radio transmission and reception; Part 1: Range 1 standalone
2.	3GPP TS 38.521-3	5G NR; User Equipment (UE) conformance specification; Radio transmission and reception; Part 3: Range 1 and Range 2 Interworking operation with other radios
3.	3GPP TS 38.521-2	5G NR; User Equipment (UE) conformance specification; Radio transmission and reception; Part 2: Range 2 standalone
4.	3GPP TS 51 010-1	2G Mobile Station (MS) conformance specification; Part 1: Conformance specification
5.	3GPP TS 36.521-1	4G Evolved Universal Terrestrial Radio Access (E-UTRA); User Equipment (UE) conformance specification; Radio transmission and reception; Part 1: Conformance testing
6.	3GPP TS 34.121-1	3G User Equipment (UE) conformance specification; Radio transmission and reception (FDD); Part 1: Conformance specification
7.	ETSI EN 300 328	Wideband transmission systems; Data transmission equipment operating in the 2,4 GHz band; Harmonised Standard for access to radio spectrum
8.	ETSI EN 301 893	5 GHz RLAN; Harmonised Standard covering the essential requirements of article 3.2 of Directive 2014/53/EU
9.	ETSI EN 302 502	Wireless Access Systems (WAS); 5,8 GHz fixed broadband data transmitting systems; Harmonised Standard covering the essential requirements of

		article 3.2 of Directive 2014/53/EU
10.	WPC GSR 45(E)	Use of low power Equipment in the frequency band 2.4 GHz to 2.4835 GHz (Exemption from Licensing Requirement) Rules, 2005.
11.	EN 301 511	Global System for Mobile communications (GSM); Mobile Stations (MS) equipment; Harmonised Standard covering the essential requirements of article 3.2 of Directive 2014/53/EU
12.	EN 301 908-13	IMT cellular networks; Harmonised Standard for access to radio spectrum; Part 13: Evolved Universal Terrestrial Radio Access (E-UTRA) User Equipment (UE)
13.	IEEE 802.3	IEEE Standard for defining the Physical (PHY) and Media Access Control (MAC) layers for wired Ethernet Local Area Networks (LANs), Metropolitan Area Networks (MANs), and Wide Area Networks (WANs).
14.	IS 16046	Guidelines for verification of rated capacity [Clause 7.3.1 of IS 16047 (Part 3):2018/IEC 61960-3: 2017] for portable sealed secondary Lithium Cells and Batteries
15.	IS 13252-1	Indian Standard Information Technology Equipment — Safety
16.	EN/IEC 62133	Safety requirements for portable sealed secondary cells, and for batteries made from them, for use in portable applications
17.	EN/IEC 61000-4-29	Electromagnetic compatibility (EMC) - Part 4-29: Testing and measurement techniques - Voltage dips, short interruptions and voltage variations on d.c. input power port immunity tests
18.	EN/IEC 61000-4-11	Electromagnetic compatibility (EMC) - Part 4-11: Testing and measurement techniques - Voltage dips, short interruptions and voltage variations

		immunity tests for equipment with input current up to 16 A per phase
19.	IEC/EN 61000-4-2	Testing and measurement techniques – Electrostatic discharge immunity test
20.	IEC/EN 61000-4-3	Testing and measurement techniques – Radiated, radiofrequency, electromagnetic field immunity test
21.	IEC/EN 61000-4-4	Electromagnetic compatibility (EMC) - Part 4-4: Testing and measurement techniques - Electrical fast transient/burst immunity test
22.	IEC/EN 61000-4-5	Electromagnetic compatibility (EMC) - Part 4-5: Testing and measurement techniques - Surge immunity test
23.	IEC/EN 61000-4-6	Electromagnetic compatibility (EMC) - Part 4-6: Testing and measurement techniques - Immunity to conducted disturbances, induced by radio-frequency fields
24.	IEC:60950-1	Information Technology Equipment Safety Package
25.	IEC:62368-1	Audio/video, information and communication technology equipment - Part 1: Safety requirements
26.	CISPR 32	Limits and methods of measurement of radio disturbance characteristics of ITE

# CHAPTER-1

## 1.1. INTRODUCTION

1.1.1 This document specifies the Generic Requirements (GR) of 'Fixed Wireless Phone' connected to the Indian Telecom Network. This document covers the Generic Requirements of Fixed Wireless Phone for supporting speech communication over mobile networks using SIM-based access. It covers its facilities, features and performance requirements for providing basic telephony and data services as an alternative to traditional Public Switched Telephone Networks (PSTN), particularly in areas lacking wired or wireless local loop infrastructure, including remote, hilly, temporary, and disaster-affected locations.

## 1.2 DESCRIPTION

1.2.1 A Fixed Wireless Phone (FWP) is a static subscriber terminal installed at the customer's premises that enables voice communication by interfacing with a licensed cellular network through a valid Subscriber Identity Module (SIM). Instead of relying on metallic pair cables, optical fiber, or direct exchange wiring, the device establishes connectivity via radio frequency access to the nearest base station. It operates as a fixed-location communication unit and is designed to remain at a designated site while providing reliable call origination and termination services. The equipment integrates essential components such as a cellular radio module, antenna system, power interface, user dialing interface, and audio circuitry to ensure seamless interaction with the telecom network.

1.2.2 From a service perspective, the FWP delivers functionality comparable to conventional fixed telephony by supporting standard numbering plans, inbound and outbound calling, and other basic voice-related features mandated by the telecom network. It serves as an effective last-mile access solution where installation of copper or fiber infrastructure is technically impractical, geographically constrained, economically non-viable, or time-

consuming. Such scenarios may include sparsely populated rural regions, mountainous terrain, border areas, temporary establishments, construction sites, and emergency or disaster-affected zones. By leveraging existing mobile network coverage, the FWP provides a cost-efficient, rapidly deployable, and scalable alternative for delivering dependable fixed voice connectivity without the need for physical wired infrastructure.

1.2.3 Based on functionality, FWPs are categorized into two types:

(a) Fixed Wireless Phone with Voice Facility Only, and

(b) Fixed Wireless Phone with Voice & Data Facility,

depending on the communication services supported by the device.

1.2.3.1 Fixed Wireless Phone with Voice Facility Only

A Fixed Wireless Phone with Voice Facility Only is a stationary customer premises equipment intended exclusively for providing circuit-switched or voice-over-cellular communication through a licensed mobile network using a valid SIM credential. The equipment is engineered to deliver fundamental telephony capabilities, enabling users to initiate and receive voice calls in accordance with the applicable national numbering plan and network signalling requirements. It does not incorporate packet data functionality, broadband access, or internet-based applications, thereby restricting its operation strictly to voice communication services. The device typically includes standard telephony interfaces such as a handset or RJ-9 port, dialing keypad, ringing mechanism, audio processing circuitry, and necessary radio modules to ensure dependable speech transmission over the cellular access network.

From an operational standpoint, this category of Fixed Wireless Phone is optimized for reliability, simplicity, and ease of deployment. By excluding data features, the design reduces system complexity, power consumption, and network resource usage, making it suitable for essential communication needs where advanced multimedia or internet services are neither required

nor feasible. Such devices are particularly advantageous in rural and sparsely populated regions, hilly or geographically challenging terrains, border locations, temporary installations, construction camps, emergency response setups, and disaster rehabilitation scenarios. In these environments, where wired access infrastructure is unavailable, damaged, or economically impractical to deploy, a voice-only FWP provides a stable, cost-effective, and rapidly deployable solution for meeting basic telecommunication requirements.

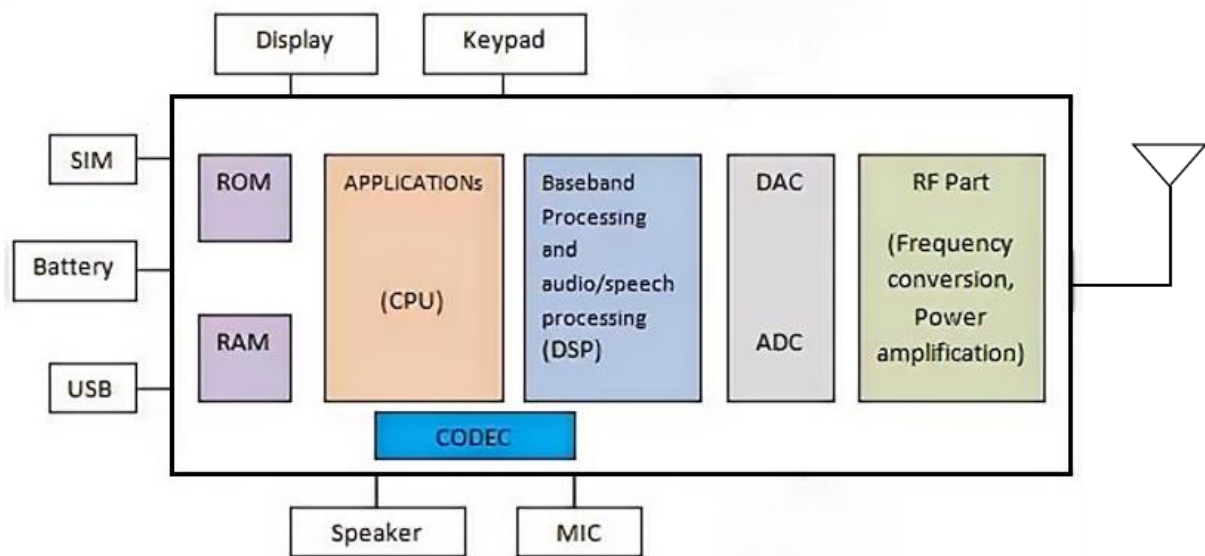

Fig 1: Block Diagram of Fixed Wireless Phone with Voice Facility Only

### 1.2.3.2 Fixed Wireless Phone with Voice & Data Facility

A Fixed Wireless Phone with Voice & Data Facility is a stationary customer premises equipment designed to deliver integrated telecommunication services by utilizing a licensed cellular network through a valid SIM credential. In addition to supporting standard voice call origination and termination in accordance with network signaling and numbering frameworks, the device is capable of providing packet-based data connectivity over the mobile access network. It facilitates simultaneous or alternate use of speech and broadband services, subject to the capabilities of the underlying radio technology and service provisioning by the operator. The equipment incorporates a cellular

communication module, antenna system, voice interface, and data handling components to ensure seamless transmission of both real-time voice traffic and IP-based data.

From a functional perspective, this category of Fixed Wireless Phone extends beyond basic telephony by enabling internet access and supporting a range of data-driven applications such as web browsing, email, enterprise connectivity, remote monitoring, and digital services. It may provide user interfaces including Ethernet ports, Wi-Fi access points, USB connectivity, or similar networking options to allow connection of computers, routers, or other compatible devices. Such equipment is particularly beneficial in locations where conventional wired broadband or copper-based landline infrastructure is unavailable, uneconomical, or time-consuming to deploy. By leveraging existing cellular coverage, it offers a scalable, rapidly deployable, and cost-efficient solution for delivering combined voice and data services in rural regions, semi-urban areas, temporary establishments, and other connectivity-constrained environments.

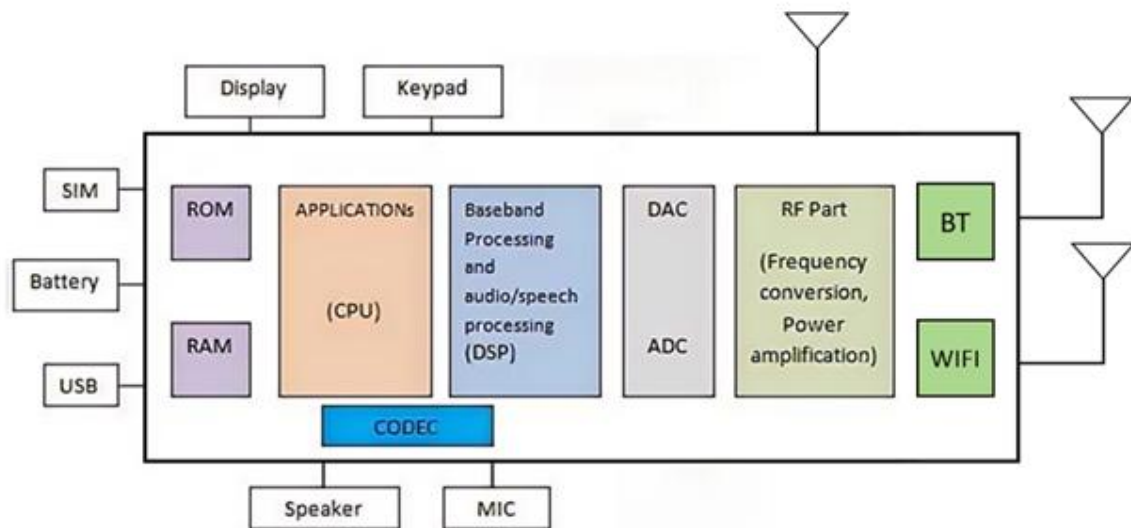

Fig 2: Block Diagram of Fixed Wireless Phone with Voice & Data Facility

### 1.3 FUNCTIONAL REQUIREMENTS

1.3.1 The FWP shall provide facilities including:

- i) LCD Display with Backlight,
- ii) Caller Line Identification,
- iii) Two-way Communication,
- iv) Three-party Conferencing,
- v) Call Waiting,
- vi) Call Forwarding/Divert,
- vii) Last Number Redial,
- viii) Supports GSM/WCDMA/VoLTE for HD voice calling over 4G-LTE networks. VoNR support for HD voice calling over 5G networks.

1.3.2 It shall have indicators to display:

- i) Battery Capacity,
- ii) Signal Strength,
- iii) Date and Time,
- iv) Charging Status,
- v) Call Status,
- vi) Power Adaptor Indication.

1.3.3 The FWP equipment may support Wi-Fi Hotspot Capability (up to 8 users) wherever applicable.

1.3.4 Additional features may include:

- i) SMS (minimum memory: 200),
- ii) Phonebook (minimum memory: 300),
- iii) Call Logs,
- iv) Speakerphone,
- v) Speed Dialing,
- vi) Adjustable Receive Volume Control,
- vii) Selectable Ring Tones,

- viii) Call Hold/Mute,
- ix) SOS Emergency Button,
- x) Phone Lock,
- xi) Battery Operation (Li-ion).

1.3.5 Optional features may include:

- i) Call recording,
- ii) Dual SIM Operation,
- iii) Bluetooth,
- iv) FM radio,
- v) Audio Player (MP3),
- vi) Keypad Auto-Lock,
- vii) Hotline function,
- viii) Call Barring,
- ix) Alarm with Snooze,
- x) Basic Calculator,
- xi) Sound Recording Function,
- xii) Colour Display,
- xiii) Headset compatibility.
- xiv) Video calling support
- xv) Camera for video calling

1.3.6 The FWP shall consist of a base unit with provision for:

- i) SIM (Mini/Standard, Micro, Nano or eSIMs),
- ii) Battery,
- iii) Charger Connection,
- iv) Fixed or Detachable Antenna,
- v) A Handset connected through a Coil Cord.

**1.3.7** The base unit shall have an Integrated Keypad and Speaker to enable Two-way Communication.

**1.3.8** The equipment shall be designed for Desktop Installation and shall operate reliably on Mains Power Supply with Battery Backup Support.

**1.3.9 Operating Frequency & Channel bandwidth**

1.3.9.1 Operating frequency and Channel bandwidth shall be as per the applicable National Frequency Allocation Plan for cellular interfaces.

1.3.9.2 Operating frequency, Channel bandwidth and EIRP shall be as per GSRs issued by WPC for operation in delicensed bands like for WiFi or Bluetooth.

1.3.9.3 The equipment shall be capable of operating in at least one of the frequency bands as per the applicable National Frequency Allocation Plan or GSRs issued by WPC.

**1.4 INTERFACE REQUIREMENTS**

The Fixed Wireless Phone (FWP) shall support and tested for at least one cellular interface from below for providing voice calling support or data support (if applicable).

**1.4.1 GSM or GPRS or EDGE**

<b>S. No.</b>	<b>Individual Parameter Name</b>	<b>Standard</b>	<b>Applicability / Remarks</b>
1.4.1.1	Transmitter Maximum output power	3GPP TS 51.010-1 Clause 13.3; EN 301 511 (GSM) Clause 4.2.5	GSM
1.4.1.2	Transmitter Maximum output power	3GPP TS 51.010-1 Clause 13.16.2; EN 301 511 (GSM) Clause 4.2.10	GPRS / EDGE
1.4.1.3	Output RF Spectrum	3GPP TS 51.010-1 Clause 13.4; EN 301 511 (GSM) Clause 4.2.6	GSM
1.4.1.4	Output RF Spectrum	3GPP TS 51.010-1 Clause 13.16.3; EN 301 511 (GSM) Clause 4.2.11	GPRS / EDGE

1.4.1.5	Spurious emissions (MS allocated a channel)	3GPP TS 51.010-1 Clause 12.1.1; EN 301 511 (GSM) Clause 4.2.12	GSM
1.4.1.6	Spurious emissions (MS in idle mode)	3GPP TS 51.010-1 Clause 12.1.2; EN 301 511 (GSM) Clause 4.2.13	GSM
1.4.1.7	Frequency Error and phase error	3GPP TS 51.010-1 Clause 13.1; EN 301 511 (GSM) Clause 4.2.1	GSM
1.4.1.8	Frequency Error and phase error	GPRS: 3GPP TS 51.010-1 Clause 13.16.1; EN 301 511 Clause 4.2.4	GPRS / EDGE
1.4.1.9	Reference sensitivity level (speech channels)	3GPP TS 51.010-1 Clause 14.2; EN 301 511 Clause 4.2.42	GSM
1.4.1.10	Adjacent Channel Rejection (speech channels)	3GPP TS 51.010-1 Clause 14.5; EN 301 511 Clause 4.2.38	GSM
1.4.1.11	Receiver blocking	3GPP TS 51.010-1 Clause 14.7.1; EN 301 511 Clause 4.2.20	GSM

#### 1.4.2 LTE or LTE-A

S.No.	Individual Parameter Name	Standard	
1.4.2.1	Maximum output power	3GPP TS 36.521-1 Clause 6.2.2	EN 301 908-13 (LTE) Clause 4.2.2
1.4.2.2	Spectrum emissions mask	3GPP TS 36.521-1 Clause 6.6.2.1	EN 301 908-13 (LTE) Clause 4.2.3
1.4.2.3	Spurious emissions	3GPP TS 36.521-1 Clauses 6.6.3.1,	EN 301 908-13 (LTE) Clause 4.2.4

		6.6.3.2, 6.6.3.3	
1.4.2.4	Receiver spurious emission	3GPP TS 36.521-1 Clause 7.9	EN 301 908-13 (LTE) Clause 4.2.10
1.4.2.5	Receiver Reference Sensitivity level	3GPP TS 36.521-1 Clause 7.3	EN 301 908-13 (LTE) Clause 4.2.12
1.4.2.6	Receiver Adjacent Channel Selectivity (ACS)	3GPP TS 36.521-1 Clause 7.5	EN 301 908-13 (LTE) Clause 4.2.6
1.4.2.7	Receiver In-band blocking	3GPP TS 36.521-1 Clause 7.6.1	EN 301 908-13 (LTE) Clause 4.2.7

### 1.4.3 WCDMA or HSPA

S. No.	Individual Parameter Name	Standard
1.4.3.1	Transmitter Maximum output power	3GPP TS 34.121-1 Clause 5.2; EN 301 908-2 (UMTS) Clause 4.2.2
1.4.3.2	Transmitter Spectrum emissions mask	3GPP TS 34.121-1 Clause 5.9; EN 301 908-2 (UMTS) Clause 4.2.3
1.4.3.3	Transmitter spurious emissions	3GPP TS 34.121-1 Clause 5.11; EN 301 908-2 (UMTS) Clause 4.2.4
1.4.3.4	Receiver spurious emission	3GPP TS 34.121-1 Clause 6.8; EN 301 908-2 (UMTS) Clause 4.2.10
1.4.3.5	Transmitter Minimum Output Power	3GPP TS 34.121-1 Clause 5.4.3; EN 301 908-2 (UMTS) Clause 4.2.5
1.4.3.6	Receiver Reference sensitivity level	3GPP TS 34.121-1 Clause 6.2; EN 301 908-2 (UMTS) Clause 4.2.13
1.4.3.7	Receiver Adjacent Channel Selectivity (ACS)	3GPP TS 34.121-1 Clause 6.4; EN 301 908-2 (UMTS) Clause 4.2.6
1.4.3.8	Receiver In-band	3GPP TS 34.121-1 Clause 6.5.2.1; EN 301

	blocking	908-2 (UMTS) Clause 4.2.7
1.4.3.9	Frequency Stability	3GPP TS 34.121-1 Clause 5.3; EN 301 908-2 (UMTS)

#### 1.4.4 5G NR (FR1)

S. No.	Individual Parameter Name	Standard
1.4.4.1	Additional spectrum emission mask-Transmitter	3GPP TS 38.521-1 Clause 6.5.2.3
1.4.4.2	Additional spectrum emission mask for UL MIMO	3GPP TS 38.521-1 Clause 6.5D.2.3
1.4.4.3	Additional spurious emissions	3GPP TS 38.521-1 Clause 6.5.3.3
1.4.4.4	Additional spurious emissions for UL MIMO	3GPP TS 38.521-1 Clause 6.5D.3.3
1.4.4.5	Adjacent channel selectivity	3GPP TS 38.521-1 Clause 7.5
1.4.4.6	Adjacent channel selectivity for 2DL CA	3GPP TS 38.521-1 Clause 7.5A.1
1.4.4.7	Adjacent channel selectivity for UL-MIMO	3GPP TS 38.521-1 Clause 7.5D
1.4.4.8	General spurious emissions- Transmitter	3GPP TS 38.521-1 Clause 6.5.3.1
1.4.4.9	General spurious emissions for UL MIMO	3GPP TS 38.521-1 Clause 6.5D.3.1
1.4.4.10	In-band Blocking for CA-2DL CA	3GPP TS 38.521-1 Clause 7.6A.2.1
1.4.4.11	Inband Blocking	3GPP TS 38.521-1 Clause 7.6.2
1.4.4.12	Inband blocking for UL-MIMO	3GPP TS 38.521-1 Clause 7.6D.2
1.4.4.13	Minimum output power	3GPP TS 38.521-1 Clause 6.3.1
1.4.4.14	Narrow band blocking	3GPP TS 38.521-1 Clause 7.6.4

1.4.4.15	Narrow band blocking for CA-2DL CA	3GPP TS 38.521-1 Clause 7.6A.4.1
1.4.4.16	Narrow band blocking for UL- MIMO	3GPP TS 38.521-1 Clause 7.6D.4
1.4.4.17	NR ACLR	3GPP TS 38.521-1 Clause 6.5.2.4.1
1.4.4.18	NR ACLR for UL MIMO	3GPP TS 38.521-1 Clause 6.5D.2.4.1
1.4.4.19	Out-of-band blocking	3GPP TS 38.521-1 Clause 7.6.3
1.4.4.20	Out-of-band blocking for UL- MIMO	3GPP TS 38.521-1 Clause 7.6D.3
1.4.4.21	Reference sensitivity power level	3GPP TS 38.521-1 Clause 7.3.2
1.4.4.22	Reference sensitivity power level for 2DL CA without exception	3GPP TS 38.521-1 Clause 7.3A.1
1.4.4.23	Reference sensitivity power level for UL-MIMO	3GPP TS 38.521-1 Clause 7.3D.2
1.4.4.24	Spectrum Emission Mask-5G NR FR1	3GPP TS 38.521-1 Clause 6.5.2.2
1.4.4.25	Spectrum emission Mask for UL MIMO	3GPP TS 38.521-1 Clause 6.5D.2.2
1.4.4.26	Spurious emission for 2DL CA	3GPP TS 38.521-1 Clause 7.9A.1
1.4.4.27	Spurious emission for UE co- existence	3GPP TS 38.521-1 Clause 6.5.3.2
1.4.4.28	Spurious emission for UE co- existence for UL MIMO	3GPP TS 38.521-1 Clause 6.5D.3.2
1.4.4.29	Spurious emissions-5G NR FR1	3GPP TS 38.521-1 Clause 7.9
1.4.4.30	Spurious response	3GPP TS 38.521-1 Clause 7.7
1.4.4.31	Spurious response for 2DL CA	3GPP TS 38.521-1 Clause 7.7A.1
1.4.4.32	Spurious response for UL-MIMO	3GPP TS 38.521-1 Clause 7.7D

1.4.4.33	UE Maximum Output Power	3GPP TS 38.521-1 Clause 6.2.1
1.4.4.34	UE maximum output power for UL-MIMO	3GPP TS 38.521-1 Clause 6.2D.1
1.4.4.35	UE maximum output power reduction for UL-MIMO	3GPP TS 38.521-1 Clause 6.2D.2
1.4.4.36	UTRA ACLR	3GPP TS 38.521-1 Clause 6.5.2.4.2
1.4.4.37	UTRA ACLR for UL MIMO	3GPP TS 38.521-1 Clause 6.5D.2.4.2
1.4.4.38	Wide band Intermodulation	3GPP TS 38.521-1 Clause 7.8.2
1.4.4.39	Wide band Intermodulation for CA-2DL CA	3GPP TS 38.521-1 Clause 7.8A.2.1
1.4.4.40	Wide band Intermodulation for UL-MIMO	3GPP TS 38.521-1 Clause 7.8D.2

#### 1.4.5 5G NR – FR1 and FR2 Interworking with Other Radios

S. No.	Individual Parameter Name	Standard
1.4.5.1	Additional Spectrum emissions mask for inter-band EN-DC within FR1	3GPP TS 38.521-3 Clause 6.5B.2.3.2
1.4.5.2	Additional Spurious emissions for inter-band EN-DC within FR1	3GPP TS 38.521-3 Clause 6.5B.4.3
1.4.5.3	Adjacent channel leakage ratio for Inter-band EN-DC including FR2 2CCs	3GPP TS 38.521-3 Clause 6.5B.2.4.3
1.4.5.4	Adjacent channel leakage ratio for inter-band EN-DC within FR1	3GPP TS 38.521-3 Clause 6.5B.2.3.3
1.4.5.5	Adjacent channel selectivity for inter-band EN-DC within FR1 2CCs	3GPP TS 38.521-3 3GPP TS 38.521-3
1.4.5.6	Adjacent channel selectivity for intra-band contiguous EN-DC	3GPP TS 38.521-3 Clause 7.5B.1

	2CCs	
1.4.5.7	General spurious emissions for inter-band EN-DC within FR1	3GPP TS 38.521-3 Clause 6.5B.3.3.1
1.4.5.8	General spurious emissions for intra-band contiguous EN-DC	3GPP TS 38.521-3 Clause 6.5B.3.1.1
1.4.5.9	Inband blocking for inter-band EN-DC within FR1-2CCs	3GPP TS 38.521-3 Clause 7.6B.2.3
1.4.5.10	Inband blocking for intra-band contiguous EN-DC in FR1-2CCs	3GPP TS 38.521-3 Clause 7.6B.2.1
1.4.5.11	Minimum output power for EN-DC Inter-band including FR2	3GPP TS 38.521-3 Clause 6.3B.1.4
1.4.5.12	Minimum Output Power for intra-band contiguous EN-DC	3GPP TS 38.521-3 Clause 6.3B.1.1
1.4.5.13	Minimum output power for intra-band EN-DC within FR1	3GPP TS 38.521-3 Clause 6.3B.1.3
1.4.5.14	Narrow band blocking for inter band EN DC within FR1 2CCs	3GPP TS 38.521-3 Clause 7.6B.4.3
1.4.5.15	Narrow band blocking for intra band contiguous EN DC in FR1 2CCs	3GPP TS 38.521-3 Clause 7.6B.4.1
1.4.5.16	Out-of-band blocking for inter-band EN-DC within FR1-2CCs	3GPP TS 38.521-3 Clause 7.6B.3.3
1.4.5.17	Out-of-band blocking for intra-band contiguous EN-DC in FR1-2CCs	3GPP TS 38.521-3 Clause 7.6B.3.1
1.4.5.18	Reference sensitivity for EN-DC within FR1 3CCs	3GPP TS 38.521-3 Clause 7.3B.2.3_1.1
1.4.5.19	Reference sensitivity for inter-band EN-DC including FR2	3GPP TS 38.521-3 Clause 7.3B.2.4
1.4.5.20	Reference sensitivity for inter-band EN-DC within FR1 2CCs	3GPP TS 38.521-3 Clause 7.3B.2.3
1.4.5.21	Reference sensitivity for intra-band contiguous EN-DC 2CCs	3GPP TS 38.521-3 Clause 7.3B.2.1

1.4.5.22	Spectrum emissions mask for inter- band EN-DC within FR1	3GPP TS 38.521-3 Clause 6.5B.2.3.1
1.4.5.23	Spectrum emissions mask for inter-band EN-DC including FR2 (2 CCs)	3GPP TS 38.521-3 Clause 6.5B.2.4.1
1.4.5.24	Spurious emission band UE co-existence for intra-band contiguous EN-DC	3GPP TS 38.521-3 Clause 6.5B.3.1.2
1.4.5.25	Spurious emissions band UE co-existence for inter-band within FR1	3GPP TS 38.521-3 Clause 6.5B.3.3.2
1.4.5.26	Spurious Emissions for EN DC within FR1 3CCs	3GPP TS 38.521-3 Clause 7.9B.3 1.1
1.4.5.27	Spurious Emissions for inter band EN DC within FR1 2CCs	3GPP TS 38.521-3 Clause 7.9B.3
1.4.5.28	Spurious emissions for intra band contiguous EN DC in FR1 2CCs	3GPP TS 38.521-3 Clause 7.9B.1
1.4.5.29	Spurious Response for inter band EN DC within FR1 2CCs	3GPP TS 38.521-3 Clause 7.7B.3
1.4.5.30	Spurious Response for intra band contiguous EN DC in FR1 2CCs	3GPP TS 38.521-3 Clause 7.7B.1
1.4.5.31	UE Maximum Output Power for Inter-Band EN-DC including FR2 - EIRP and TR	3GPP TS 38.521-3 Clause 6.2B.1.4.1
1.4.5.32	UE Maximum Output Power for Inter-Band EN-DC including FR2 - Spherical Coverage	3GPP TS 38.521-3 Clause 6.2B.1.4.2
1.4.5.33	UE Maximum Output Power for Inter-Band EN-DC within FR1	3GPP TS 38.521-3 Clause 6.2B.1.3
1.4.5.34	UE Maximum Output Power for Intra-Band Contiguous EN-DC	3GPP TS 38.521-3 Clause 6.2B.1.1
1.4.5.35	Wideband Intermodulation for inter band EN DC in FR1 2CCs	3GPP TS 38.521-3 Clause 7.8B.2.3

1.4.5.36	Wideband Intermodulation for intra band contiguous EN DC in FR1	3GPP TS 38.521-3 Clause 7.8B.2.1
----------	---	----------------------------------

#### 1.4.6 5G NR (FR2)

S. No.	Individual Parameter Name	Standard
1.4.6.1	Adjacent channel leakage ratio	3GPP TS 38.521-2 Clause 6.5.2.3
1.4.6.2	Minimum Output Power-Transmitter	3GPP TS 38.521-2 Clause 6.3.1
1.4.6.3	Reference sensitivity power level	3GPP TS 38.521-2 Clause 7.3.2
1.4.6.4	Spectrum Emission Mask-5G NR FR2	3GPP TS 38.521-2 Clause 6.5.2.1
1.4.6.5	UE maximum output power-EIRP and TRP	3GPP TS 38.521-2 Clause 6.2.1.1
1.4.6.6	UE maximum output power-Spherical coverage	3GPP TS 38.521-2 Clause 6.2.1.2
1.4.6.7	UE maximum output power reduction	3GPP TS 38.521-2 Clause 6.2.2
1.4.6.8	UE maximum output power with additional requirements	3GPP TS 38.521-2 Clause 6.2.3

#### 1.4.7 Bluetooth Low Energy (BLE)

S. No.	Parameter Name	Standards	Test Set up
1.4.7.1	Frequency of Operation of Interface	2.4 GHz to 2.4835 GHz (As per WPC GSR 45(E))	
1.4.7.2	EIRP for Interface	≤ 4 W (36 dBm) As per WPC GSR 45(E)	Test as per ETSI EN 300 328 V2.2.2 (2019-07) clause 5.4.2.2

1.4.7.3	Maximum Transmit Power / RF Output Power of Interface	$\leq 1$ W (30 dBm) As per WPC GSR 45(E) (ETSI EN 300 328 V2.2.2 (2019-07) clause 4.3.1.2 or 4.3.2.2 may be referred)	Test as per ETSI EN 300 328 V2.2.2 (2019-07) clause 5.4.2.2
1.4.7.4	Power Spectral Density	As per ETSI EN 300 328 V2.2.2 (2019-07) clause 4.3.2.3 (Only for non-FHSS equipment)	Test as per ETSI EN 300 328 V2.2.2 (2019-07) clause 5.4.3
1.4.7.5	Duty cycle, Tx-Sequence, Tx-gap	As per ETSI EN 300 328 V2.2.2 (2019-07) clause 4.3.1.3 or 4.3.2.4 (Only for non-adaptive equipment)	Test as per ETSI EN 300 328 V2.2.2 (2019-07) clause 5.4.2
1.4.7.6	Accumulated Transmit time, Frequency Occupation & Hopping Sequence	As per ETSI EN 300 328 V2.2.2 (2019-07) clause 4.3.1.4 (Only for FHSS equipment)	Test as per ETSI EN 300 328 V2.2.2 (2019-07) clause 5.4.4
1.4.7.7	Hopping Frequency Separation	As per ETSI EN 300 328 V2.2.2 (2019-07) clause 4.3.1.5 (Only for FHSS equipment)	Test as per ETSI EN 300 328 V2.2.2 (2019-07) clause 5.4.5
1.4.7.8	Medium Utilization (MU) factor	As per ETSI EN 300 328 V2.2.2 (2019-07) clause 4.3.1.6 or 4.3.2.5 (Only for non-Adaptive equipment)	Test as per ETSI EN 300 328 V2.2.2 (2019-07) clause 5.4.2
1.4.7.9	Adaptivity	As per ETSI EN 300 328 V2.2.2 (2019-07) clause 4.3.1.7 or 4.3.2.6 (Only for Adaptive equipment)	Test as per ETSI EN 300 328 V2.2.2 (2019-07) clause 5.4.6
1.4.7.10	Occupied Channel Bandwidth	As per ETSI EN 300 328 V2.2.2 (2019-07) clause 4.3.1.8 or 4.3.2.7	Test as per ETSI EN 300 328 V2.2.2 (2019-07) clause

			5.4.7
1.4.7.11	Transmitter unwanted emission in the OOB domain	As per ETSI EN 300 328 V2.2.2 (2019-07) clause 4.3.1.9 or 4.3.2.8	Test as per ETSI EN 300 328 V2.2.2 (2019-07) clause 5.4.8
1.4.7.12	Transmitter unwanted emissions in the spurious domain	As per ETSI EN 300 328 V2.2.2 (2019-07) clause 4.3.1.10 or 4.3.2.9	Test as per ETSI EN 300 328 V2.2.2 (2019-07) clause 5.4.9
1.4.7.13	Receiver spurious emissions	As per ETSI EN 300 328 V2.2.2 (2019-07) clause 4.3.1.11 or 4.3.2.10	Test as per ETSI EN 300 328 V2.2.2 (2019-07) clause 5.4.10
1.4.7.14	Receiver Blocking	As per ETSI EN 300 328 V2.2.2 (2019-07) clause 4.3.1.12 or 4.3.2.11	Test as per ETSI EN 300 328 V2.2.2 (2019-07) clause 5.4.11.2
1.4.7.15	Geo-location capability	As per ETSI EN 300 328 V2.2.2 (2019-07) clause 4.3.1.13 or 4.3.2.12 (Only for equipment with geo-location capability)	—

#### 1.4.8 Wi-Fi

S. No.	Parameter Name	Standard/Parameter	Limits/ Values
1.4.8.1	Frequency for WiFi equipment	DoT WPC GSR No. 45(E), 1048E	2.4 GHZ Band: 2.4-2.4835 GHz as per WPC GSR 45E 5 GHz Band: 5.150-5.250 GHz, 5.250-5.350GHz, 5.470-5.725 GHz, 5.725-5.875 GHz as per WPC GSR 1048E

1.4.8.2	EIRP for all equipment operating in 2.4 GHz	As per Latest NFAP and GSRs issued by DoT WPC	$\leq 4$ W (36 dBm). Maximum output power of transmitter $\leq 1$ W (30 dBm) in spread of 10 MHz or higher. (As per GSR 45(E))
1.4.8.3	EIRP for RLAN / WLAN equipment operating in 5 GHz	Latest NFAP and GSRs issued by DoT WPC	Maximum conducted output power and antenna gain as per limits mentioned in WPC GSR 1048(E) based on type of equipment, operational/deployment characteristics and specific conditions related to antenna gain for different frequency bands: 5.150–5.250 GHz, 5.250–5.350 GHz, 5.470–5.725 GHz and 5.725–5.875 GHz. EIRP limit = Maximum conducted output power + Antenna Gain
1.4.8.4	Radio Conformance for all Wi-Fi equipment operating in 2.4 GHz	ETSI EN 300 328 or FCC CFR47 Part 15.247 or FCC CFR47 Part 15.249	Refer to ETSI EN 300 328 Clause 4.2 – Applicable category of equipment on basis of FHSS and non-FHSS. Clause 4.3 and sub clauses – Conformance tests as per category in clause 4.2 with limits in sub clause 5 – Test methods. For equipment conforming to FCC CFR 47 Part 15.247 / FCC CFR 47 Part 15.249, Radio Conformance shall be taken as indicated in the standard. However, the test method shall be as per Clause 5 of ETSI EN 300 328.

1.4.8.5	Radio Conformance for WLAN/WLAN Wi-Fi equipment operating in 5 GHz	ETSI EN 301 893 or FCC CFR 47 Part 15.407	Test requirements and limits as per EN 301 893 for frequency bands 5.150–5.250 GHz, 5.250–5.350 GHz, 5.470–5.725 GHz, and 5.725–5.875 GHz. Or test requirements and limits as per FCC CFR 47 Part 15.407 for the same frequency bands.
---------	--	---	--

#### 1.4.9 10/100/1000 BASE-T Ethernet

Link speed and auto-negotiation test (GE): As per IEEE 802.3

#### 1.4.10 10/100 BASE-T Ethernet

Link speed and auto-negotiation test: As per IEEE 802.3

### 1.5 QUALITY REQUIREMENT

1.5.1 The supplier/manufacturer shall conform to ISO 9001:2015 certifications. A quality plan describing the quality assurance system followed by the manufacturer shall be required to be submitted.

1.5.2 All the requirements described in chapter 2 of this document are suggestive requirements and shall be decided by the purchaser at the time of procurement/tender as per its requirements. However, the requirements described in Chapter-2 will not be tested/ verified by TEC at the time of initial certification.

### 1.6 EMI/EMC REQUIREMENTS

These requirements are applicable for purposely built hardware or a physical entity only. (These requirements shall be as per TEC Standard No. TEC11016:2016 as modified/amended from time to time).

Clause	Parameter	Standard
1.	Conducted and Radiated Emission	CISPR 32 Class-B
2.	Immunity to Electrostatic discharge:	IEC-61000-4-2

	Contact discharge level 2 { $\pm$ 4 kV}	Performance Criteria-B, Clause 9
3.	Immunity to Electrostatic discharge: Air discharge level 3 { $\pm$ 8 kV}	IEC-61000-4-2 Performance Criteria-B, Clause 9
4.	Immunity to radiated RF: a) Radio Frequency: 80 MHz to 1 GHz, Electromagnetic field: 3V/m b) Radio Frequency: 800 MHz to 960 MHz, Electromagnetic field: 10V/m c) Radio Frequency: 1.4 GHz to 6 GHz, Electromagnetic field: 10V/m	IEC 61000-4-3 (2010); Performance Criteria-A, Clause 9
5.	Immunity to fast transients (burst): Test Level 2: a) 1 kV for AC/DC power port b) 0.5 kV for signal / control / data / telecom lines.	IEC 61000-4-4 (2012); Performance Criteria-B, Clause 9
6.	Immunity to surges: AC/DC ports a) 2 kV peak open circuit voltage for line to ground b) 1kV peak open circuit voltage for line to line	IEC 61000-4-5 (2014) Performance Criteria-B, Clause 9
7.	Immunity to surges: Telecom ports a) 2 kV peak open circuit voltage for line to ground coupling. b) 2 kV peak open circuit voltage for line-to-line coupling.	IEC 61000-4-5 (2014) Performance Criteria-C, Clause 9
8.	Immunity to conducted disturbance induced by Radio frequency fields:	IEC 61000-4-6 (2013) Performance Criteria-A,

	Under the test level 2 {3 V r.m.s.} in the frequency range 150 kHz-80 MHz for AC / DC lines and Signal /Control/telecom lines.	Clause 9
9.	<p>Immunity to voltage dips &amp; short interruptions (applicable to only ac mains power input ports, if any):</p> <p>Limits: -</p> <p>a) a voltage dip corresponding to a reduction of the supply voltage of 30% for 500ms (i.e., 70% supply voltage for 500ms)</p> <p>b) a voltage dip corresponding to a reduction of the supply voltage of 60% for 200ms; (i.e.,40% supply voltage for 200ms)</p> <p>c) a voltage interruption corresponding to a reduction of supply voltage of &gt; 95% for 5s.</p> <p>d) a voltage interruption corresponding to a reduction of supply voltage of &gt;95% for 10ms.</p>	<p>IEC 61000-4-11 (2004):</p> <p>a) Performance Criteria B for Reduction of Supply 30% for 500ms or Dip to reduction of 60% for 100ms.</p> <p>b) Performance Criteria C for Reduction of 60% for 200ms.</p> <p>c) Performance criteria C for Voltage Interruption&gt;95% for 5 s (Note: In case of Battery back-up performance criteria A is applicable).</p> <p>d) Performance Criteria B for Voltage Interruption &gt;95% duration :10ms (Note: In case of Battery back-up Performance Criteria A is applicable for above conditions.)</p>
10.	<p>Immunity to voltage dips &amp; short interruptions (applicable to only DC power input ports, if any):</p> <p>a) Voltage Interruption with 0% of supply for 10ms.</p>	<p>IEC 61000-4-29(2000)</p> <p>a) Applicable Performance Criteria shall be B.</p> <p>b) Applicable Performance Criteria shall be C.</p>

	<p>b) Voltage Interruption with 0% of supply for 30ms, 100ms, 300ms and 1000ms.</p> <p>c) Voltage dip corresponding to 40% &amp; 70% of supply for 10ms, 30 ms.</p> <p>d) Voltage dip corresponding to 40% &amp; 70% of supply for 100ms, 300 ms and 1000 ms.</p> <p>e) Voltage variations corresponding to 80% and 120%of supply for 100 ms to 10s as per Table 1c of IEC 61000-4-29.</p>	<p>c) Applicable Performance Criteria shall be B.</p> <p>d) Applicable Performance Criteria shall be C.</p> <p>Applicable Performance Criteria shall be B.</p>
--	--	--

## 1.7 SAFETY REQUIREMENTS

1.7.1 The equipment shall conform to relevant safety requirements as per

- a) IS 13252 (Part 1): A2:2015/IEC 60950-1 A2:2013/ 62368-1:2018 or Latest for Audio / Video, Information and Communication Technology Equipment &
- b) IS 16046 (Part 2): 2018 or IEC 62133-2: 2017 applicable if the equipment is battery powered

as prescribed under Table no. 1 of the TEC document ‘SAFETY REQUIREMENTS OF TELECOMMUNICATION EQUIPMENT’: TEC10009: 2024.

## 1.8 SECURITY REQUIREMENTS

1.8.1 The Security related requirements for the FWP shall comply with ITSAR of FWP (Fixed Wireless Phone) device as and when published by NCCS.

## CHAPTER-2

### 2.1 Information for the procurer of product

- 2.1.1 Interfaces and features which are optional (i.e. mentioned in this GR as may) needs to be examined by the procurer and suitably specified in the tender conditions as per their requirement specific to the procurer.

DRAFT

## ABBREVIATIONS

AC	Alternating Current
AP	Access Point
BLE	Bluetooth Low Energy
CAB	Conformity Assessment Body
CFR	Code of Federal Regulations
CISPR	International Special Committee on Radio Interference
DC	Direct Current
DNS	Domain Name System
EDGE	Enhanced Data Rates for GSM Evolution
EIRP	Equivalent Isotropically Radiated Power
EMC	Electromagnetic Compatibility
EMI	Electromagnetic Interference
ETSI	European Telecommunications Standards Institute
FCC	Federal Communications Commission
FM	Frequency Modulation
FR1	Frequency Range 1
FR2	Frequency Range 2
FWP	Fixed Wireless Phone
GPS	Global Positioning System
GPRS	General Packet Radio Service
GSM	Global System for Mobile Communications
GSR	General Statutory Rules
HD	High Definition
HSPA	High Speed Packet Access
IEC	International Electrotechnical Commission
IEEE	Institute of Electrical and Electronics Engineers
IMT	International Mobile Telecommunications
IP	Internet Protocol
IPv6	Internet Protocol Version 6
IS	Indian Standard
ISO	International Organization for Standardization
ITE	Information Technology Equipment
ITSAR	Indian Telecom Security Assurance Requirements

LAN	Local Area Network
LCD	Liquid Crystal Display
LTE	Long Term Evolution
LTE-A	Long Term Evolution Advanced
MAC	Media Access Control
MAN	Metropolitan Area Network
MP3	MPEG Audio Layer III
MS	Mobile Station
MTCTE	Mandatory Testing and Certification of Telecom Equipment
NCCS	National Centre for communication Security
NFAP	National Frequency Allocation Plan
NR	New Radio
PHY	Physical Layer
PSTN	Public Switched Telephone Network
RF	Radio Frequency
RJ-9	Registered Jack-9
RLAN	Radio Local Area Network
SIM	Subscriber Identity Module
SMS	Short Message Service
SOS	Save Our Souls
UE	User Equipment
USB	Universal Serial Bus
VoLTE	Voice over Long Term Evolution
WAN	Wide Area Network
WAS	Wireless Access Systems
WCDMA	Wideband Code Division Multiple Access
Wi-Fi	Wireless Fidelity
WPC	Wireless Planning and Coordination Wing

----- End of Document -----

**ANNEXURE-A**

**NAME OF (MANUFACTURER / STAKEHOLDER): .....**

**Organization Name: .....**

**I. COMMENTS ON Draft GR on “ Fixed Wireless Phone”:**

<b>Clause No.</b>	<b>TEC GR Name</b>	<b>TEC Document No.</b>	<b>Remarks, if any</b>